



SPECIFICATIONS

CUSTOMER	:	CDE012
SAMPLE CODE	:	SH800480T028-ZHA
MASS PRODUCTION CODE	:	PH800480T028-ZHA
SAMPLE VERSION	:	01
SPECIFICATIONS EDITION	:	004
DRAWING NO. (Ver.)	:	LMD-PH800480T028-ZHA(Ver.001)
PACKAGING NO. (Ver.)	:	PKG-PH800480T028-ZHA(Ver.001)

Customer Approved

Date:

Approved	Checked	Designer
廖志豪 Rex Liao	張慶源 Yuan Chang	陳宗淇 Howard Chen

- Preliminary specification for design input
- Specification for sample approval

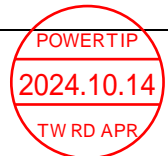

POWERTIP TECH. CORP.

Headquarters: No.8, 6 th Road, Taichung Industrial Park, Taichung, Taiwan 台中市 407 工業區六路 8 號	TEL: 886-4-2355-8168 FAX: 886-4-2355-8166	E-mail: sales@powertip.com.tw Http://www.powertip.com.tw
---	--	--

History of Version

<u>Date</u> <small>(mm / dd / yyyy)</small>	<u>Ver.</u>	<u>Edi.</u>	<u>Description</u>	<u>Page</u>	<u>Design by</u>
06/24/2024	01	001	Preliminary.	-	Howard
08/01/2024	01	002	Frist Sample	-	Howard
08/22/2024	01	003	Modify HS VS Pin Description	12	Howard
10/11/2024	01	004	Modufy Timing Characteristics	13 14	Howard

Contents

1. SPECIFICATIONS

- 1.1 Features
- 1.2 Mechanical Specifications
- 1.3 Absolute Maximum Ratings
- 1.4 DC Electrical Characteristics
- 1.5 Optical Characteristics
- 1.6 Backlight Characteristics

2. MODULE STRUCTURE

- 2.1 Counter Drawing
- 2.2 Interface Pin Description
- 2.3 Timing Characteristics

3. QUALITY ASSURANCE SYSTEM

- 3.1 Quality Assurance Flow Chart
- 3.2 Inspection Specification

4. RELIABILITY TEST

- 4.1 Reliability Test Condition

5. PRECAUTION RELATING PRODUCT HANDLING

- 5.1 Safety
- 5.2 Handling
- 5.3 Storage
- 5.4 Terms of Warranty

Appendix:

- 1.LCM Drawing
- 2.LCM Packaging Specifications

1. SPECIFICATIONS

1.1 Features

<u>Item</u>	<u>Standard Value</u>
Display Resolution	800 * 3 (RGB) * 480 Dots
LCD Type	Full Viewing Angle, Normally Black , Transmissive type
Screen size(inch)	4.3 inch
Color configuration	RGB Vertical Strip
Backlight Type	White LED B/L
Weight	43g
Interface	Parallel RGB (Data), SPI (Configuration)
ROHS	THIS PRODUCT CONFORMS THE ROHS OF PTC Detail information please refer website : http://www.powertip.com.tw/news_detail.php?Key=1&cID=1

1.2 Mechanical Specifications

<u>Item</u>	<u>Standard Value</u>	<u>Unit</u>
Outline Dimension	105.5(W) x 67.2(L) x 2.6(H)	mm

LCD panel

<u>Item</u>	<u>Standard Value</u>	<u>Unit</u>
Active Area	95.04 (W) x 53.856(L)	mm
Pixel Size	0.1188(W) * 0.1122(H)	mm

Note: For detailed information please refer to LCM drawing

1.3 Absolute Maximum Ratings

Module

Item	Symbol	Condition	Min.	Max.	Unit	Remark
Power Supply for TFT Panel	VDD	GND=0	-0.3	5.0	V	
Power Supply for Backlight Unit	VCC	GND=0	-0.3	+20.0	V	
Operating Temperature	T _{OP} (Ts)	Note 1	-20	70	°C	
Storage Temperature	T _{ST} (Ta)	Note 2	-30	80	°C	
Storage Humidity	H _D	Ta ≤ 60 °C	-	90	%RH	

The absolute maximum rating values of this product are not allowed to be exceeded at any time. Should a module be used with any of the absolute maximum ratings exceeded, the characteristics of the module may not be recovered, or in an extreme case, the module may be permanently destroyed.

Note 1: Ts is the temperature of panel's surface

Note 2: Ta is the ambient temperature of samples

1.4 DC Electrical Characteristics

Module

GND = 0V, Ta = 25°C

Item	Symbol	Condition	Min.	Typ.	Max.	Unit
Power Supply for TFT Panel	VDD	GND=0V	3.0	3.3	3.6	V
Power Supply for Backlight Unit	VCC	GND=0V	5	12	15	V
Input Voltage for TFT Panel	V _{IH}	GND=0V	0.7VDD	-	VDD	V
	V _{IL}	GND=0V	0	-	0.3VDD	
Supply Current for TFT Panel	IDD	IDD@VDD=3.3V	-	160	240	mA
Supply Current for Backlight Unit	ICC	ICC@VCC=5V	-	190	285	
Supply Current for Backlight Unit	ICC	ICC@VCC=12V	-	70	105	
Input Voltage for PWM Signal	V _{PH}	GND=0V	1.6	-	-	V
	V _{PL}	GND=0V	-	-	0.8	V
Dimming Clock Rate	fP	GND=0V	0.1	-	8	KHz

1.5 Optical Characteristics

TFT LCD Module

VDD= 3.3 V, Ta=25°C

Item	Symbol		Condition	Min.	Typ.	Max.	unit	-
Response time	Tr+Tf		Ta = 25°C θX, θY = 0°	-	41	62	ms	Note 2
Viewing angle	Top	θY+	CR ≥ 10		80	-	Deg.	Note 4
	Bottom	θY-			80	-		
	Left	θX-			80	-		
	Right	θX+			80	-		
Contrast ratio	CR			500	600	-	-	Note 3
Color of CIE Coordinate	White	X	Ta = 25°C θX, θY = 0°	0.26	0.31	0.36	-	Note1
		Y		0.32	0.37	0.42		
	Red	X		0.54	0.59	0.64		
		Y		0.31	0.36	0.41		
	Green	X		0.30	0.35	0.40		
		Y		0.54	0.59	0.64		
	Blue	X		0.08	0.13	0.18		
		Y		0.05	0.10	0.15		
Average Brightness Pattern=white display (With B/L & T/P) *2	IV		VCC=12.0V PWM="High" (Duty=100%)	800	1000	-	cd/m2	Note1
Uniformity (With B/L & T/P) *1	Δ B		VCC=12.0V PWM="High" (Duty=100%)	70	-	-	%	Note1

Note 1:

*1: $\Delta B = B(\min) / B(\max) * 100\%$

*2: Measurement Condition for Optical Characteristics:

a: Environment: $25^{\circ}\text{C} \pm 5^{\circ}\text{C}$ / $60 \pm 20\%$ R.H, no wind, dark room below 10 Lux at typical lamp current and typical operating frequency

b: Measurement Distance: 500 ± 50 mm, ($\theta = 0^{\circ}$)

c: Equipment: TOPCON BM-7 fast, (field 1°), after 10 minutes operation

d: The uncertainty of the C.I.E coordinate measurement ± 0.01 , Average Brightness $\pm 4\%$

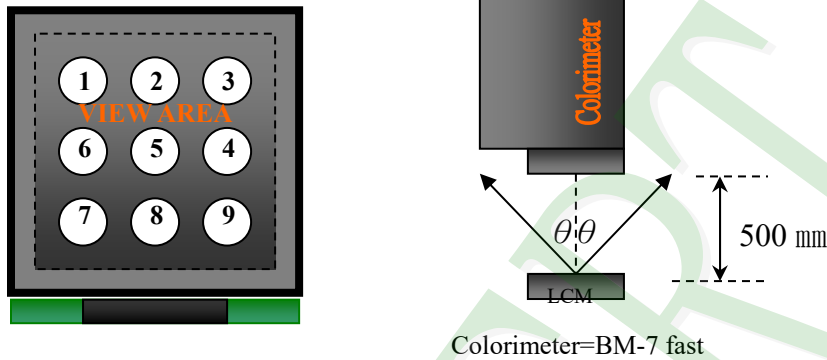

To be measured at the center area of panel with a viewing cone of 1° by Topcon luminance meter BM-7, after 10 minutes operation (module)

Note 2: Definition of response time:

The output signals of photo detector are measured when the input signals are changed from "black" to "white" (falling time) and from "white" to "black" (rising time), respectively. The response time is defined as the time interval between the 10% and 90% of Amplitudes.

Refer to figure as below:

Normally White



Normally Black

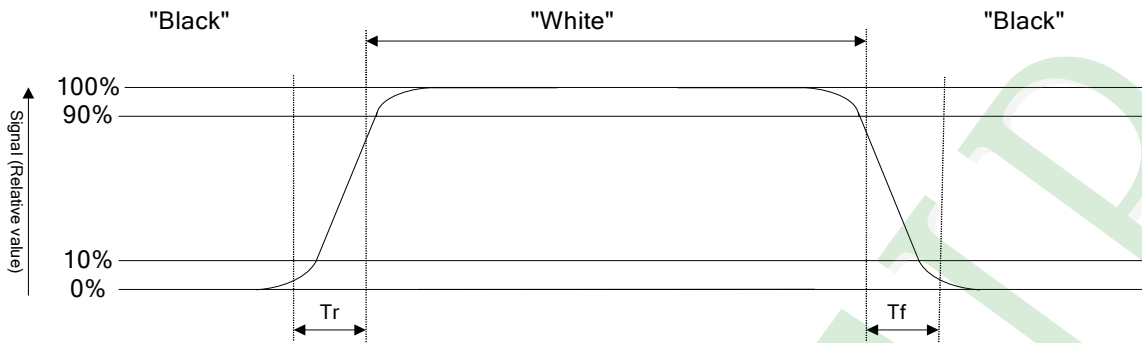

Note 3: Definition of contrast ratio:

Contrast ratio is calculated with the following formula

$$\text{Contrast ratio (CR)} = \frac{\text{Photo detector output when LCD is at "White" state}}{\text{Photo detector output when LCD is at "Black" state}}$$

Note 4: Definition of viewing angle:

Refer to figure as below:

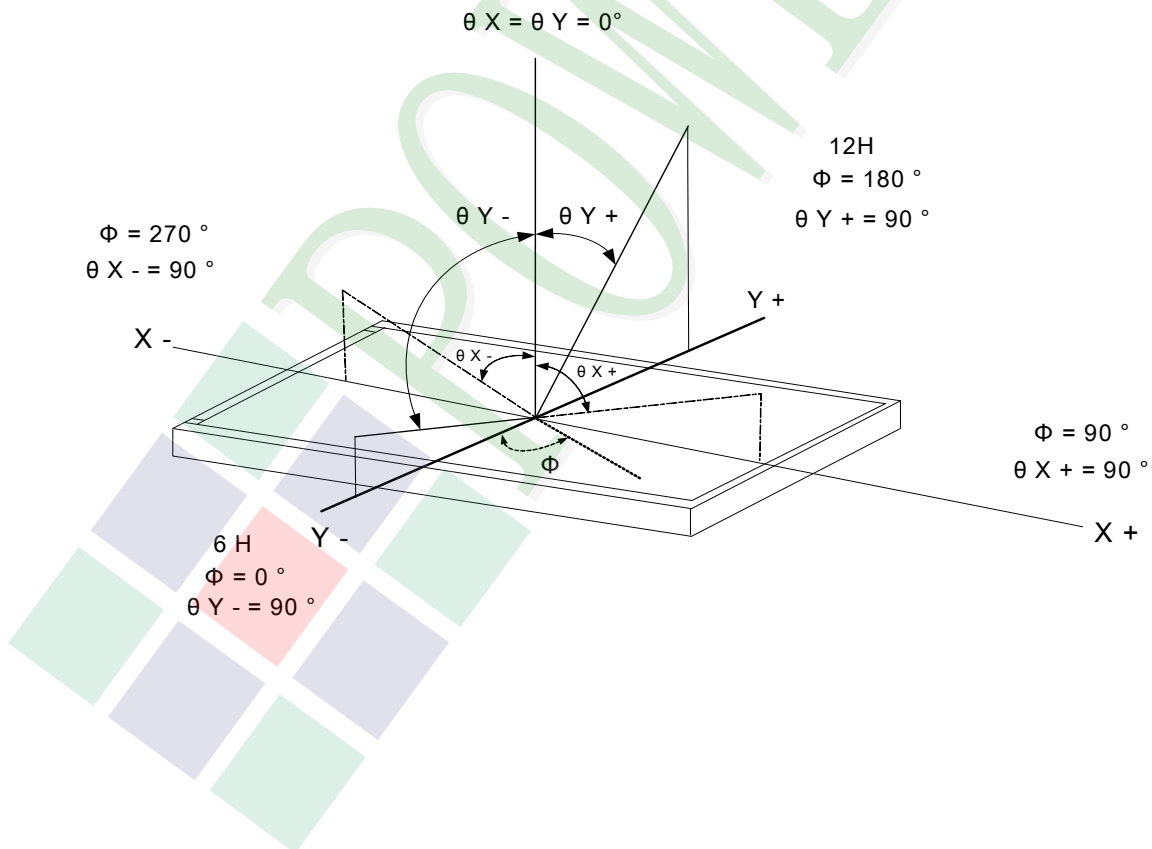

1.6 Backlight Characteristics

Maximum Ratings

<u>Item</u>	<u>Symbol</u>	<u>Min.</u>	<u>Max.</u>	<u>Unit</u>	<u>Remark</u>
LED Forward Current	I_F	-	60	mA	-
LED Reverse Voltage	V_R	-	5	V	
Power Dissipation	PD		1224	mW	

Electrical / Optical Characteristics

<u>Item</u>	<u>Symbol</u>	<u>Min.</u>	<u>Typ.</u>	<u>Max.</u>	<u>Unit</u>	<u>Remark</u>
LED Voltage	V_L	16.8	19.2	20.4	V	Note1
LED Current	I_L	-	40	-	mA	-
LED life time	-	50000	-	-	Hr	Note2

Note 1: The LED Supply Voltage is defined by the number of LED at $T_a=25^{\circ}\text{C}$ and $I_L=40\text{ mA}$.

Note 2: The "LED life time" is defined as the module brightness decrease to 50% original brightness at $T_a=25^{\circ}\text{C}$ and $I_L=40\text{ mA}$. The LED life time could be decreased if operating I_L is larger than 40 mA.

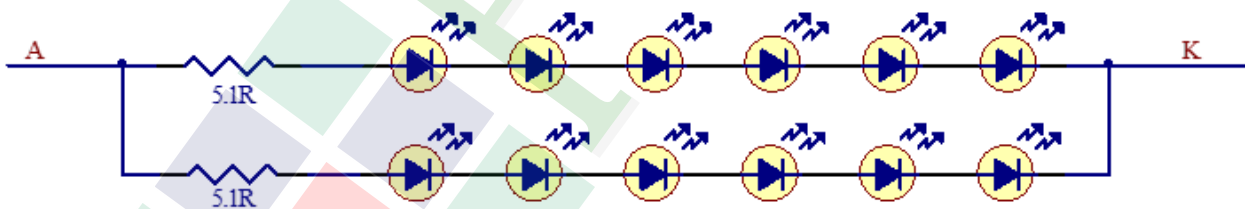

2. Module Structure

2.1 Counter Drawing

2.1.1 LCM Mechanical Diagram

* See Appendix

2.1.2 Block Diagram

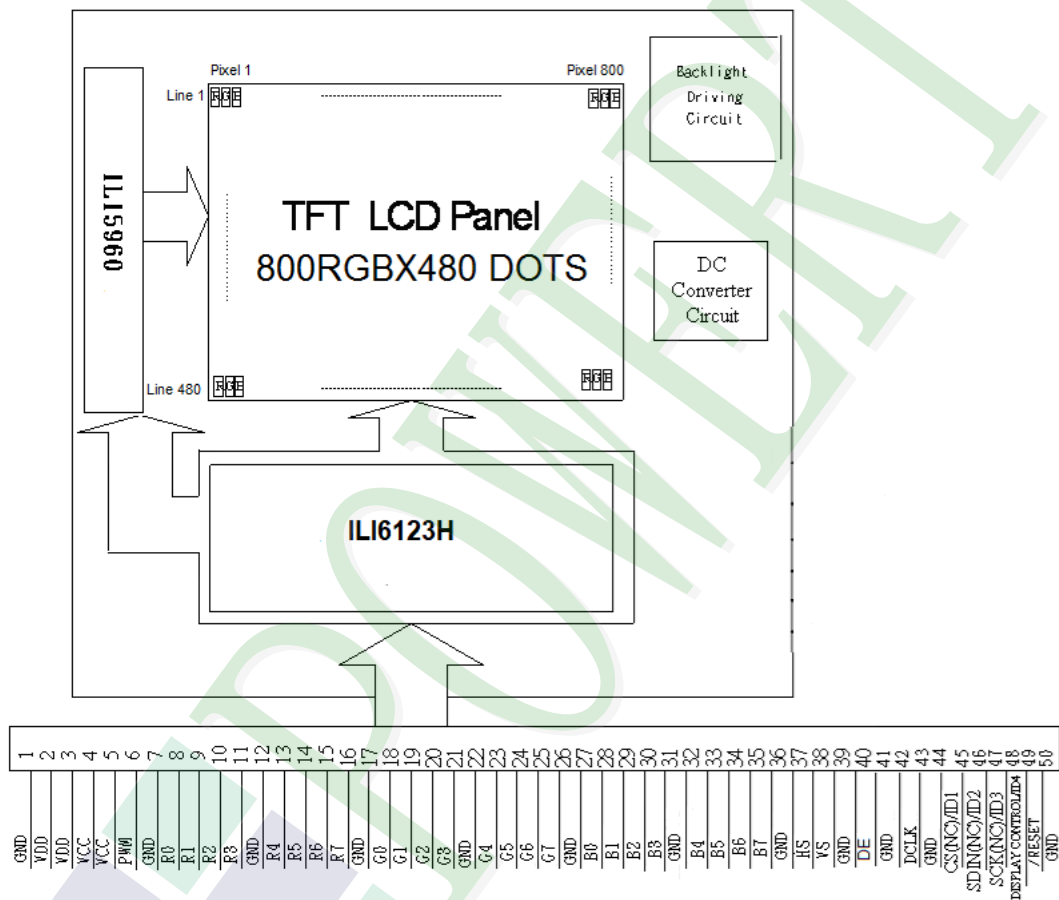

2.2 Interface Pin Description

TFT LCM Interface

<u>Pin#</u>	<u>Name</u>	<u>Description</u>
1	GND	Power ground.
2	VDD	Power for Digital Circuit.
3	VDD	Power for Digital Circuit.
4	VCC	Power For LED backlight.
5	VCC	Power For LED backlight.
6	PWM	Shutdown & Dimming control input for backlight. Do not allow this pin to float. "Hi" =100%, "Low" = 0%.
7	GND	Power ground.
8	R0	Red Data.
9	R1	Red Data.
10	R2	Red Data.
11	R3	Red Data.
12	GND	Power ground.
13	R4	Red Data.
14	R5	Red Data.
15	R6	Red Data.
16	R7	Red Data.
17	GND	Power ground.
18	G0	Green Data.
19	G1	Green Data.
20	G2	Green Data.
21	G3	Green Data.
22	GND	Power ground.
23	G4	Green Data.
24	G5	Green Data.
25	G6	Green Data.
26	G7	Green Data.
27	GND	Power ground.
28	B0	Blue Data.
29	B1	Blue Data.

Pin#	Name	Description
30	B2	Blue Data.
31	B3	Blue Data.
32	GND	Power ground.
33	B4	Blue Data.
34	B5	Blue Data.
35	B6	Blue Data.
36	B7	Blue Data.
37	GND	Power ground.
38	HS	Line synchronization signal. Horizontal Sync Input. This model operates in DE MODE. You can connect HS and VS to GND
39	VS	Frame synchronization signal. Vertical Sync Input. This model operates in DE MODE. You can connect HS and VS to GND
40	GND	Power ground.
41	DE	Data Enable.
42	GND	Power ground.
43	DCLK	Sample clock. Data will be latched at the falling edge of DCLK.
44	GND	Power ground.
45	CS/ ID1	Serial communication chip selection/ID[4:1]These pins select LCM type. See NOTE 1
46	SDIN/ ID2	Serial communication data/ ID[4:1]These pins select LCM type. See NOTE 1
47	SCK/ ID3	Serial communication clock/ ID[4:1]These pins select LCM type. See NOTE 1
48	DISPLAY CONTROL / ID4	Display Enable(Hi Active)./ ID[4:1]These pins select LCM type. See NOTE 1
49	/RESET	Global Reset (Low Active).
50	GND	Power ground.

Note1: ID Pins Definition: Follow 5.0" Module Setting

	PIN 45 ID1	PIN 46 ID2	PIN 47 ID3	PIN 48 ID4
3.5" Module	X	0	0	X
4.3" Module	X	1	0	X
5.0" Module	X	0	1	X
7.0" Module	X	1	1	X

1. Resistor = 10k ohm
2. "X" = No use

2.3 Timing Characteristics

2.3.1 Input Clock and Data Timing Diagram

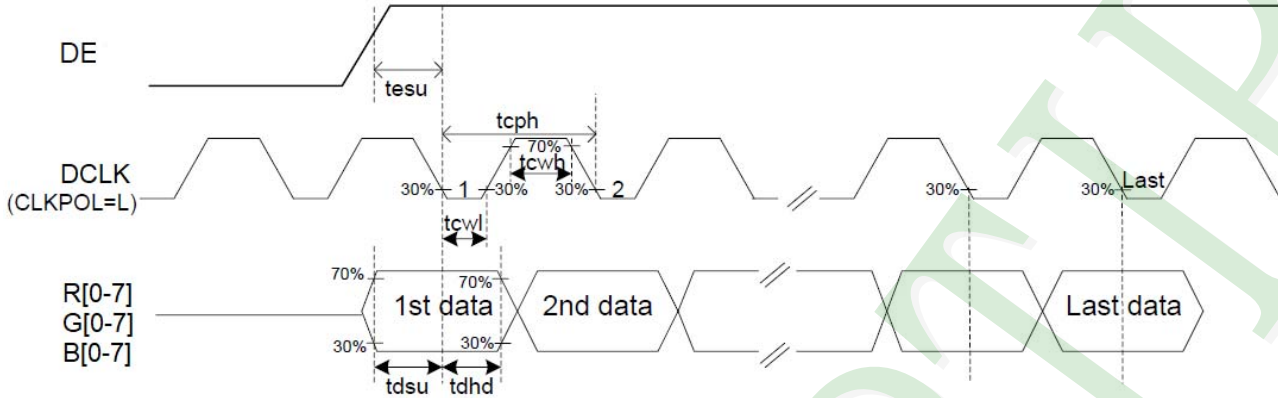

Parameter	Symbol	Min	Typ	Max	Unit	
DCLK Frequency	Fclk	--	40	50	MHz	VDD = 3.0V ~3.6V
DCLK Cycle Time	Tclk	20	25		ns	
DCLK Pulse Duty	Tcwh	40	50	60	%	Tclk
Time from HS to Source Output	Thso	-	64		CLKIN	
Time from HS to LD	Thld	-	64		CLKIN	
Time from HS to STV	Thstv	-	2		CLKIN	
Time from HS to CKV	Thckv	-	20		CLKIN	
Time from HS to OEV	Thoev		4		CLKIN	
LD Pulse Width	Twld		10		CLKIN	
CKV Pulse Width	Twckv		66		CLKIN	
OEV Pulse Width	Twoev		74		CLKIN	

2.3.2 Timing Characteristic

2.3.2.1: DE Mode

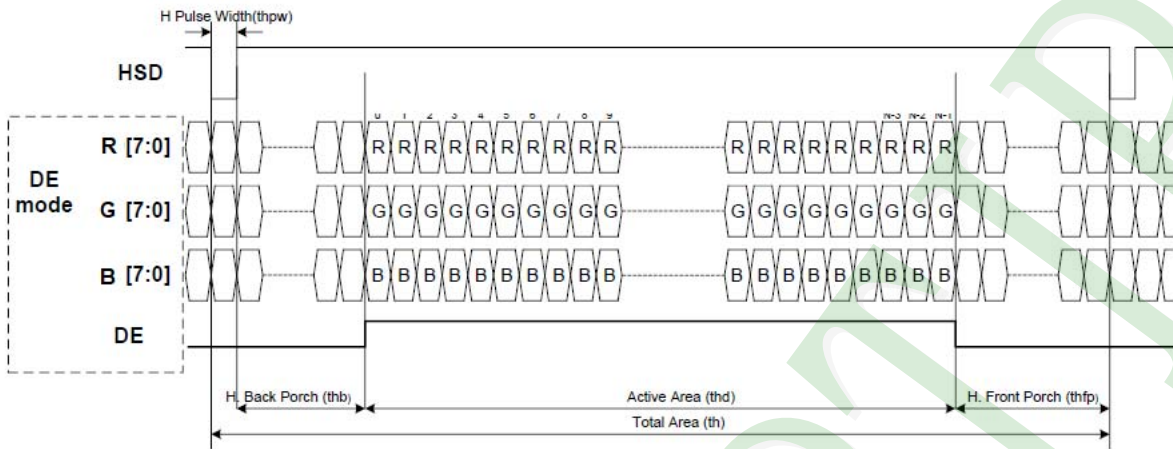

Parallel 24-bit RGB Interface Timing Table

Parameter	Symbol	Min	Typ.	Max	Unit
CLK frequency	fclk	-	33.3	50	MHz
DE H period	$thpw+thb+thd+thfp = th$	908	1056	-	DCLK
DE H-Display Area	thd	800			DCLK
DE H-Blanking	th-thd	120	200	210	DCLK
DE V period	$tpw+tvb+tvd+tvfp=$	500	512	-	DCLK
DE V-Display Area	tvd	480			th
DE V-Blanking	tv-tvd	20	32	-	th

2.3 SPI timing

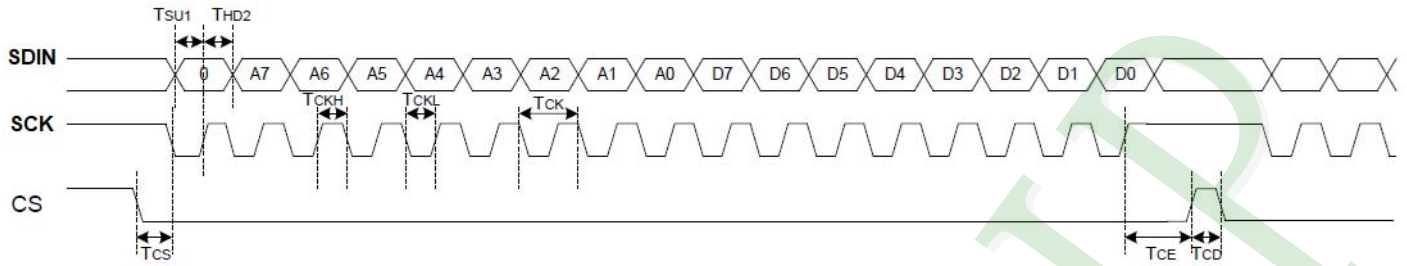

SPI Interface Timing Table

<u>Parameter</u>	<u>Symbol</u>	<u>Min</u>	<u>Typ.</u>	<u>Max</u>	<u>Unit</u>
SCK period	T_{CK}	60	-	-	ns
SCK high width	T_{CKH}	30	-	-	ns
SCK low width	T_{CKL}	30	-	-	ns
Data setup time	T_{SU1}	12	-	-	ns
Data hold time	T_{HD1}	12	-	-	ns
CS to SCK setup time	T_{CS}	20	-	-	ns
CS to SDIN hold time	T_{CE}	20	-	-	ns
CS high pulse width	T_{CD}	50	-	-	ns

2.3.3 Power On/Off Sequence

To prevent device damage from latch up, the power ON/OFF sequence shown below must be followed.

Power ON: VDD, DGND→AVDD, AGND→V1 to V14

Power OFF: V1 to V14→AVDD, AGND→VDD, DGND

Case1: REV = L (Default)

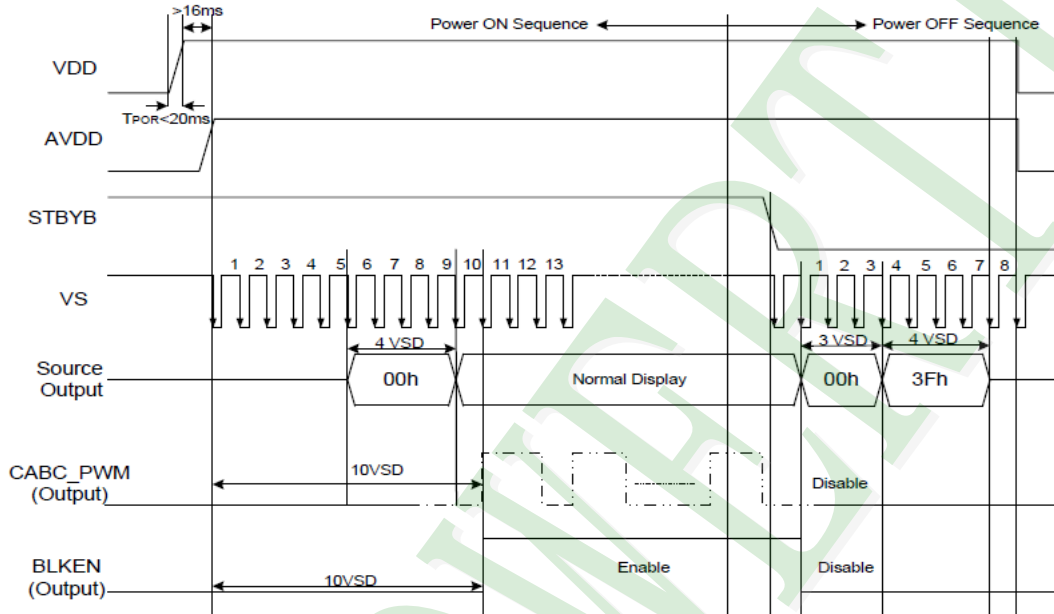

Case2: REV = H

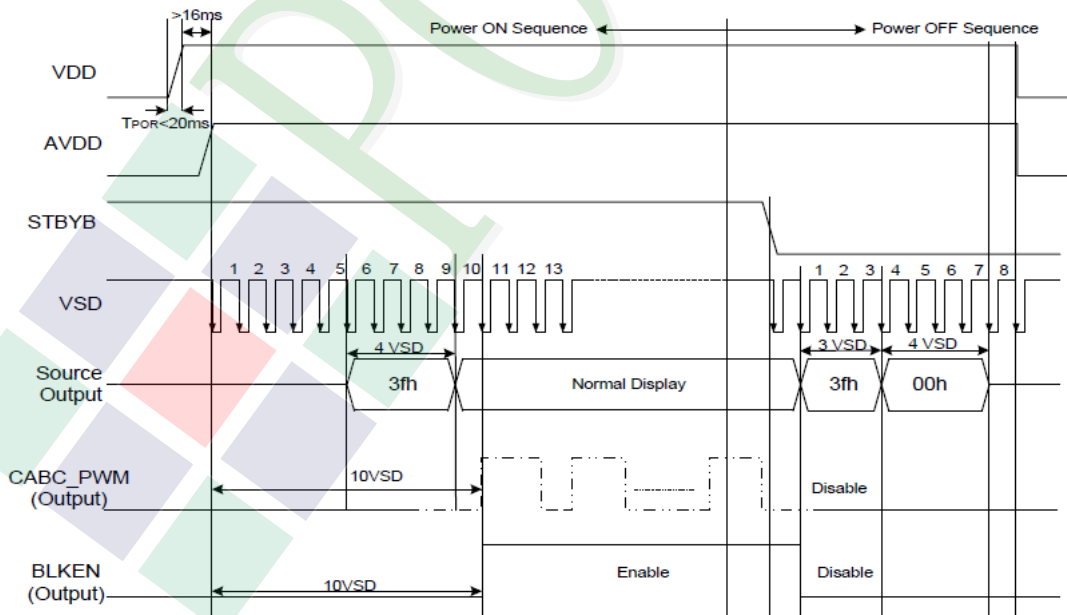

3. Quality Assurance System

3.1 Quality Assurance Flow Chart

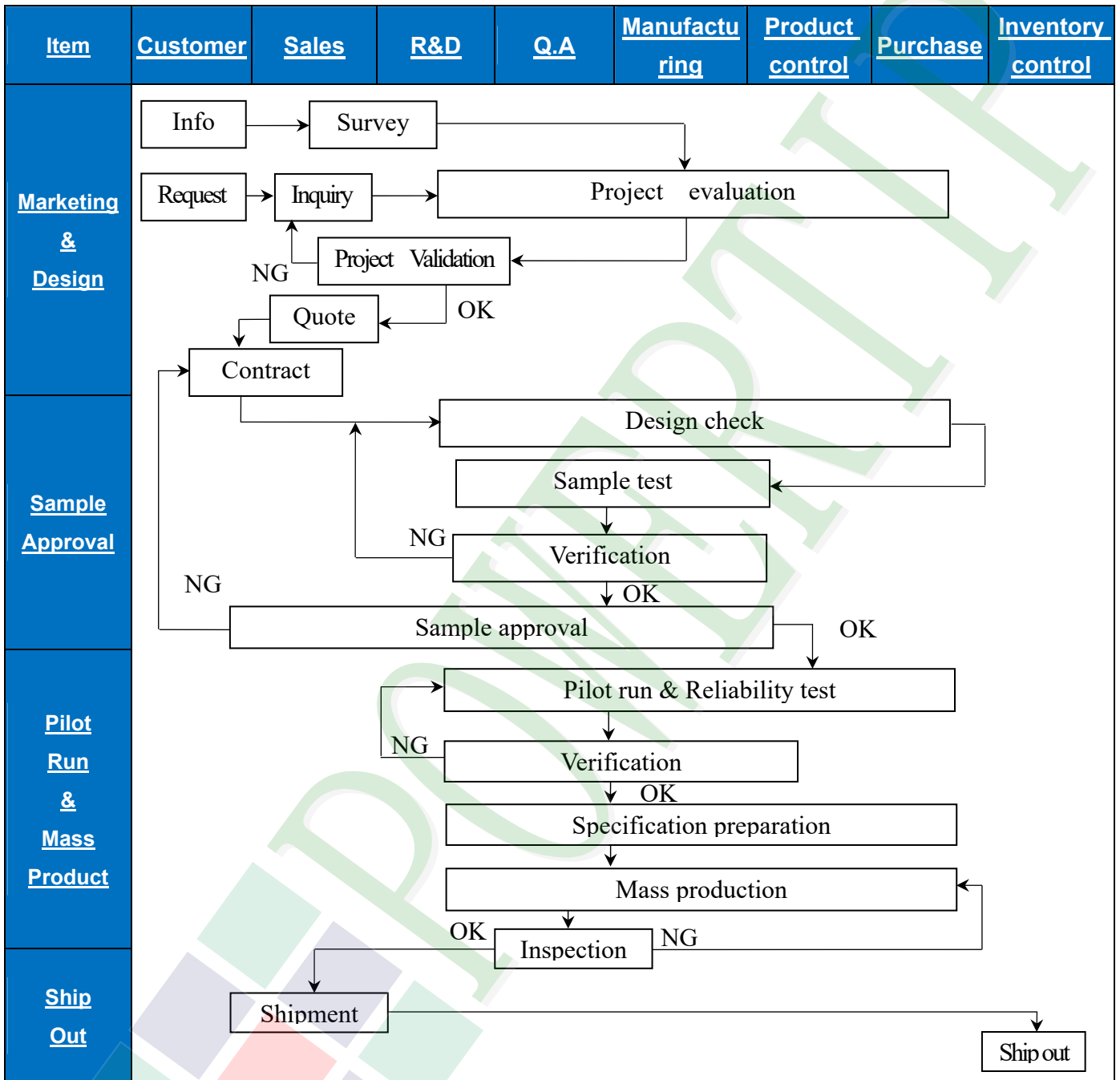

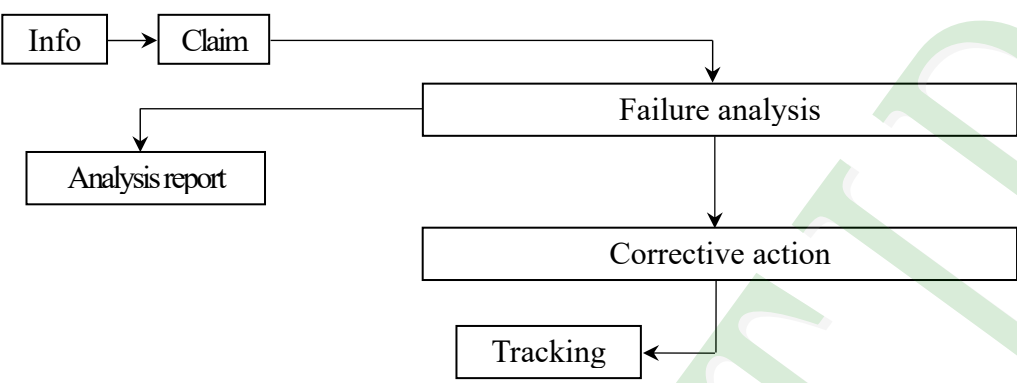
Item	Customer	Sales	R&D	Q.A	Manufacturing	Product control	Purchase	Inventory control
Sales Service	 <pre> graph TD Info[Info] --> Claim[Claim] Claim --> Failure[Failure analysis] Failure --> Report[Analysis report] Failure --> Action[Corrective action] Action --> Tracking[Tracking] </pre>							
Q.A Activity	<ol style="list-style-type: none"> 1. ISO 9001 Maintenance Activities 2. Process improvement proposal 3. Equipment calibration 4. Education And Training Activities 5. Standardization Management 							

3.2 Inspection Specification

- ◆Scope: The document shall be applied to TFT-LCD Module for 3.5" -15" (Ver.B01).
- ◆Inspection Standard: MIL-STD-105E Table Normal Inspection Single Sampling Level II.
- ◆Equipment: Gauge, MIL-STD, Powertip Tester, Sample
- ◆Defect Level: Major Defect AQL: 0. 4; Minor Defect AQL: 1. 5
- ◆OUT Going Defect Level: Sampling
- ◆Standard of the product appearance test:

a. Manner of appearance test:

- (1). The test best be under 20W×2 fluorescent light(about 300lux ~500lux) and distance of view must be at 30~40 cm.
- (2). The test direction is base on about around 45° of vertical line.

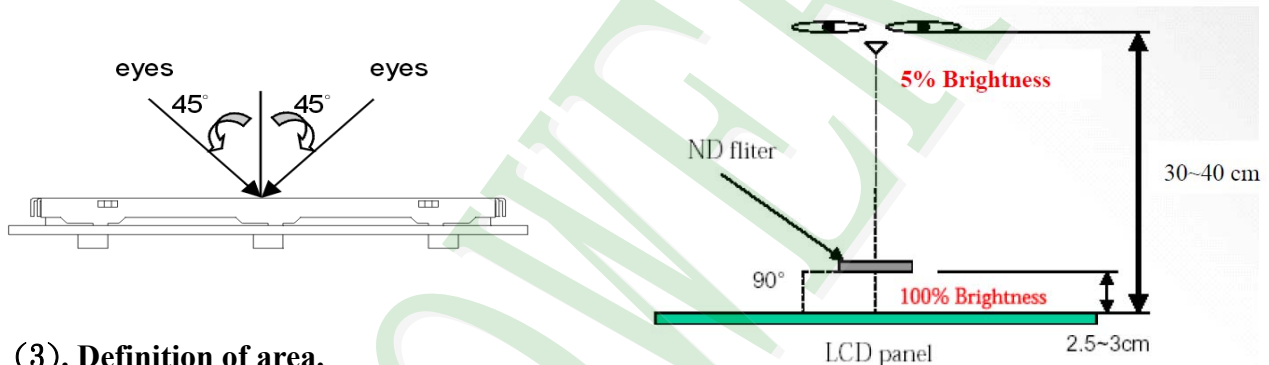

(3). Definition of area.

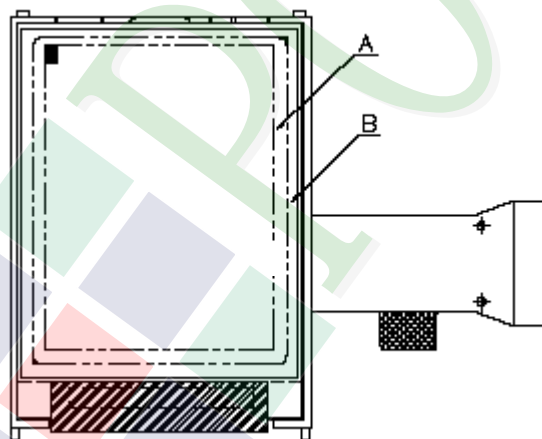

A area: viewing area

B area: Outside of viewing area

(4). Standard of inspection : (Unit : mm)

◆Specification For TFT-LCD Module 3.5” ~15” :
(Ver.B01)

<u>NO</u>	<u>Item</u>	<u>Criterion</u>	<u>Level</u>										
01	Product condition	1. 1 The part number is inconsistent with work order of production.	Major										
		1. 2 Mixed product types.	Major										
		1. 3 Assembled in inverse direction.	Major										
02	Quantity	2. 1 The quantity is inconsistent with work order of production.	Major										
03	Outline dimension	3. 1 Product dimension and structure must conform to structure diagram.	Major										
04	Electrical Testing	4. 1 Missing line character and icon.	Major										
		4. 2 No function or no display.	Major										
		4. 3 Display malfunction.	Major										
		4. 4 LCD viewing angle defect.	Major										
		4. 5 Current consumption exceeds product specifications.	Major										
		4. 6 Mura cannot be seen through 5% ND filter at 50% Gray, should be judged by the viewing angle of 90 degree.	Minor										
05	Dot defect (Bright dot, Dark dot) On -display	<table border="1" data-bbox="561 1245 1273 1556"> <thead> <tr> <th><u>Item</u></th> <th><u>Acceptance (O'ty)</u></th> </tr> </thead> <tbody> <tr> <td>Bright Dot</td> <td>≤ 4</td> </tr> <tr> <td>Dark Dot</td> <td>≤ 5</td> </tr> <tr> <td>Joint Dot</td> <td>≤ 3</td> </tr> <tr> <td>Total</td> <td>≤ 7</td> </tr> </tbody> </table>	<u>Item</u>	<u>Acceptance (O'ty)</u>	Bright Dot	≤ 4	Dark Dot	≤ 5	Joint Dot	≤ 3	Total	≤ 7	Minor
		<u>Item</u>	<u>Acceptance (O'ty)</u>										
Bright Dot	≤ 4												
Dark Dot	≤ 5												
Joint Dot	≤ 3												
Total	≤ 7												
5.1 Inspection pattern: full white, full black, Red, Green and blue screens. 5.2 It is defined as dot defect if defect area $> 1/2$ dot. 5.3 The distance between two dot defect ≥ 5 mm. 5.4 Bright dot : Dots appear bright and unchanged in visible with 5% ND filter is defined. 5.5 Tiny bright dot: bright dot area $\leq 1/2$ dot. a. Dots appear bright and unchanged in visible with 5% ND filter is defined defect and is judged in accordance with 6.1 b. Dots invisible with 5% ND Filter is Ignored.													

◆ Specification For TFT-LCD Module 3.5" ~15" :

(Ver.B01)

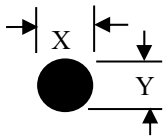
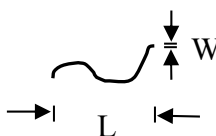
NO	Item	Criterion	Level																																			
06	Black or white Dot, scratch, contamination Round type  $\Phi = (x + y) / 2$ Line type 	6.1 Round type (Non-display or display): <table border="1"> <thead> <tr> <th rowspan="2">Dimension (diameter: Φ)</th> <th colspan="2">Acceptance (Q'ty)</th> </tr> <tr> <th>A area</th> <th>B area</th> </tr> </thead> <tbody> <tr> <td>$\Phi \leq 0.25$</td> <td colspan="2">Ignore</td> </tr> <tr> <td>$0.25 < \Phi \leq 0.50$</td> <td>5</td> <td rowspan="3">Ignore</td> </tr> <tr> <td>$\Phi > 0.50$</td> <td>0</td> </tr> <tr> <td>Total</td> <td>5</td> </tr> </tbody> </table>	Dimension (diameter: Φ)	Acceptance (Q'ty)		A area	B area	$\Phi \leq 0.25$	Ignore		$0.25 < \Phi \leq 0.50$	5	Ignore	$\Phi > 0.50$	0	Total	5	Minor																				
		Dimension (diameter: Φ)		Acceptance (Q'ty)																																		
A area	B area																																					
$\Phi \leq 0.25$	Ignore																																					
$0.25 < \Phi \leq 0.50$	5	Ignore																																				
$\Phi > 0.50$	0																																					
Total	5																																					
6.2 Line type(Non-display or display): <table border="1"> <thead> <tr> <th rowspan="2">module size</th> <th rowspan="2">Length (L)</th> <th rowspan="2">Width (W)</th> <th colspan="2">Acceptance (Q'ty)</th> </tr> <tr> <th>A area</th> <th>B area</th> </tr> </thead> <tbody> <tr> <td rowspan="5">3.5" to less 9"</td> <td>---</td> <td>$W \leq 0.03$</td> <td>Ignore</td> <td rowspan="5">Ignore</td> </tr> <tr> <td>$L \leq 10.0$</td> <td>$0.03 < W \leq 0.05$</td> <td>4</td> </tr> <tr> <td>$L \leq 5.0$</td> <td>$0.05 < W \leq 0.10$</td> <td>2</td> </tr> <tr> <td>---</td> <td>$W > 0.10$</td> <td>As round type</td> </tr> <tr> <td colspan="2">Total</td> <td>5</td> </tr> <tr> <td rowspan="4">9" to 15"</td> <td>---</td> <td>$W \leq 0.05$</td> <td>Ignore</td> <td rowspan="4">Ignore</td> </tr> <tr> <td>$L \leq 10.0$</td> <td>$0.05 < W \leq 0.10$</td> <td>5</td> </tr> <tr> <td>---</td> <td>$W > 0.10$</td> <td>As round type</td> </tr> <tr> <td colspan="2">Total</td> <td>5</td> </tr> </tbody> </table>	module size	Length (L)	Width (W)	Acceptance (Q'ty)		A area	B area	3.5" to less 9"	---	$W \leq 0.03$	Ignore	Ignore	$L \leq 10.0$	$0.03 < W \leq 0.05$	4	$L \leq 5.0$	$0.05 < W \leq 0.10$	2	---	$W > 0.10$	As round type	Total		5	9" to 15"	---	$W \leq 0.05$	Ignore	Ignore	$L \leq 10.0$	$0.05 < W \leq 0.10$	5	---	$W > 0.10$	As round type	Total		5
module size				Length (L)	Width (W)	Acceptance (Q'ty)																																
	A area	B area																																				
3.5" to less 9"	---	$W \leq 0.03$	Ignore	Ignore																																		
	$L \leq 10.0$	$0.03 < W \leq 0.05$	4																																			
	$L \leq 5.0$	$0.05 < W \leq 0.10$	2																																			
	---	$W > 0.10$	As round type																																			
	Total		5																																			
9" to 15"	---	$W \leq 0.05$	Ignore	Ignore																																		
	$L \leq 10.0$	$0.05 < W \leq 0.10$	5																																			
	---	$W > 0.10$	As round type																																			
	Total		5																																			
07	Polarizer Bubble	<table border="1"> <thead> <tr> <th rowspan="2">Dimension (diameter: Φ)</th> <th colspan="2">Acceptance (Q'ty)</th> </tr> <tr> <th>A area</th> <th>B area</th> </tr> </thead> <tbody> <tr> <td>$\Phi \leq 0.25$</td> <td>Ignore</td> <td rowspan="5">Ignore</td> </tr> <tr> <td>$0.25 < \Phi \leq 0.50$</td> <td>4</td> </tr> <tr> <td>$0.50 < \Phi \leq 0.80$</td> <td>1</td> </tr> <tr> <td>$\Phi > 0.80$</td> <td>0</td> </tr> <tr> <td>Total</td> <td>5</td> </tr> </tbody> </table>	Dimension (diameter: Φ)	Acceptance (Q'ty)		A area	B area	$\Phi \leq 0.25$	Ignore	Ignore	$0.25 < \Phi \leq 0.50$	4	$0.50 < \Phi \leq 0.80$	1	$\Phi > 0.80$	0	Total	5	Minor																			
Dimension (diameter: Φ)	Acceptance (Q'ty)																																					
	A area	B area																																				
$\Phi \leq 0.25$	Ignore	Ignore																																				
$0.25 < \Phi \leq 0.50$	4																																					
$0.50 < \Phi \leq 0.80$	1																																					
$\Phi > 0.80$	0																																					
Total	5																																					

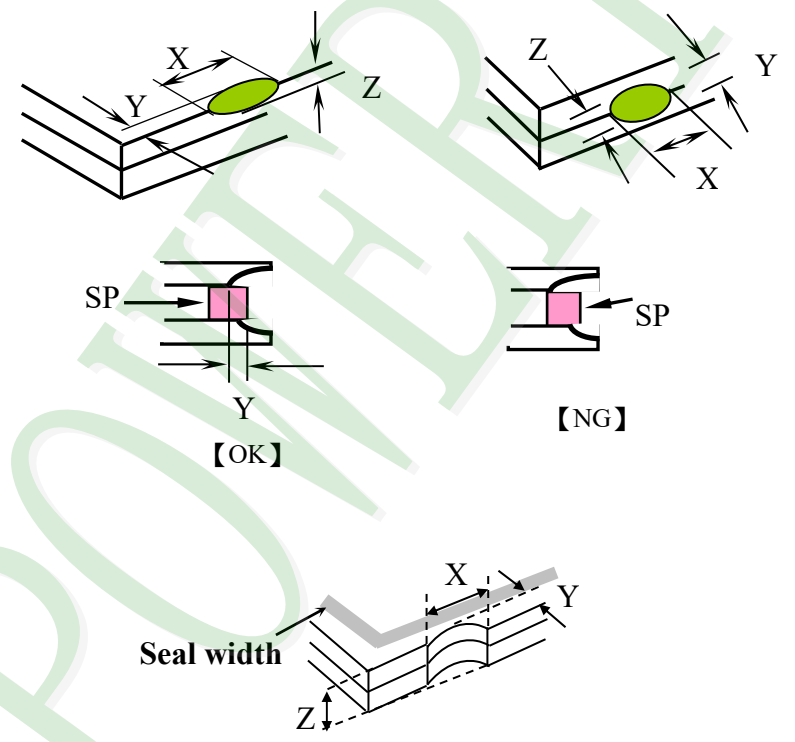
NO	Item	Criterion	Level									
08	The crack of glass	<p>Symbols :</p> <p>X: The length of crack Z: The thickness of crack T: The thickness of glass</p> <p>Y: The width of crack. W: terminal length a : LCD side length</p> <hr/> <p>8.1 General glass chip: 8.1.1 Chip on panel surface and crack between panels:</p>  <table border="1" data-bbox="539 1579 1353 1870"> <thead> <tr> <th>X</th> <th>Y</th> <th>Z</th> </tr> </thead> <tbody> <tr> <td>$\leq a$</td> <td>Crack can't enter viewing area</td> <td>$\leq 1/2 t$</td> </tr> <tr> <td>$\leq a$</td> <td>Crack can't exceed the half of SP width.</td> <td>$1/2 t < Z \leq 2 t$</td> </tr> </tbody> </table>	X	Y	Z	$\leq a$	Crack can't enter viewing area	$\leq 1/2 t$	$\leq a$	Crack can't exceed the half of SP width.	$1/2 t < Z \leq 2 t$	Minor
		X	Y	Z								
$\leq a$	Crack can't enter viewing area	$\leq 1/2 t$										
$\leq a$	Crack can't exceed the half of SP width.	$1/2 t < Z \leq 2 t$										

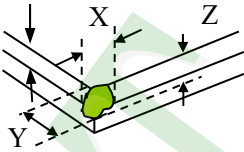
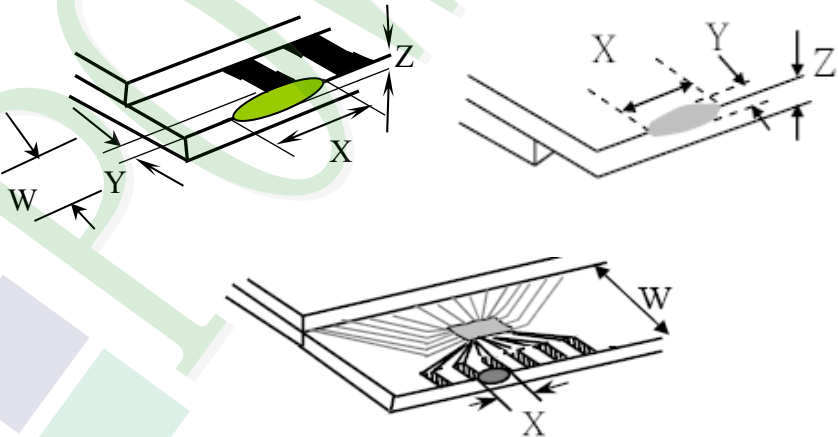
NO	Item	Criterion	Level										
08	The crack of glass	<p>Symbols :</p> <p>X: The length of crack Z: The thickness of crack t: The thickness of glass</p> <p>Y: The width of crack. W: terminal length a: LCD side length</p> <hr/> <p>8.1.2 Corner crack:</p>  <table border="1" data-bbox="520 763 1337 1055"> <thead> <tr> <th><u>X</u></th> <th><u>Y</u></th> <th><u>Z</u></th> </tr> </thead> <tbody> <tr> <td>$\leq 1/5 a$</td> <td>Crack can't enter viewing area</td> <td>$Z \leq 1/2 t$</td> </tr> <tr> <td>$\leq 1/5 a$</td> <td>Crack can't exceed the half of SP width.</td> <td>$1/2 t < Z \leq 2 t$</td> </tr> </tbody> </table>	<u>X</u>	<u>Y</u>	<u>Z</u>	$\leq 1/5 a$	Crack can't enter viewing area	$Z \leq 1/2 t$	$\leq 1/5 a$	Crack can't exceed the half of SP width.	$1/2 t < Z \leq 2 t$		
		<u>X</u>	<u>Y</u>	<u>Z</u>									
$\leq 1/5 a$	Crack can't enter viewing area	$Z \leq 1/2 t$											
$\leq 1/5 a$	Crack can't exceed the half of SP width.	$1/2 t < Z \leq 2 t$											
<p>8.2 Protrusion over terminal:</p> <p>8.2.1 Chip on electrode pad:</p>  <table border="1" data-bbox="560 1697 1347 1872"> <thead> <tr> <th></th> <th><u>X</u></th> <th><u>Y</u></th> <th><u>Z</u></th> </tr> </thead> <tbody> <tr> <td>Front</td> <td>$\leq a$</td> <td>$\leq 1/2 W$</td> <td>$\leq t$</td> </tr> <tr> <td>Back</td> <td>$\leq a$</td> <td>$\leq W$</td> <td>$\leq 1/2 t$</td> </tr> </tbody> </table>		<u>X</u>	<u>Y</u>	<u>Z</u>	Front	$\leq a$	$\leq 1/2 W$	$\leq t$	Back	$\leq a$	$\leq W$	$\leq 1/2 t$	Minor
	<u>X</u>	<u>Y</u>	<u>Z</u>										
Front	$\leq a$	$\leq 1/2 W$	$\leq t$										
Back	$\leq a$	$\leq W$	$\leq 1/2 t$										

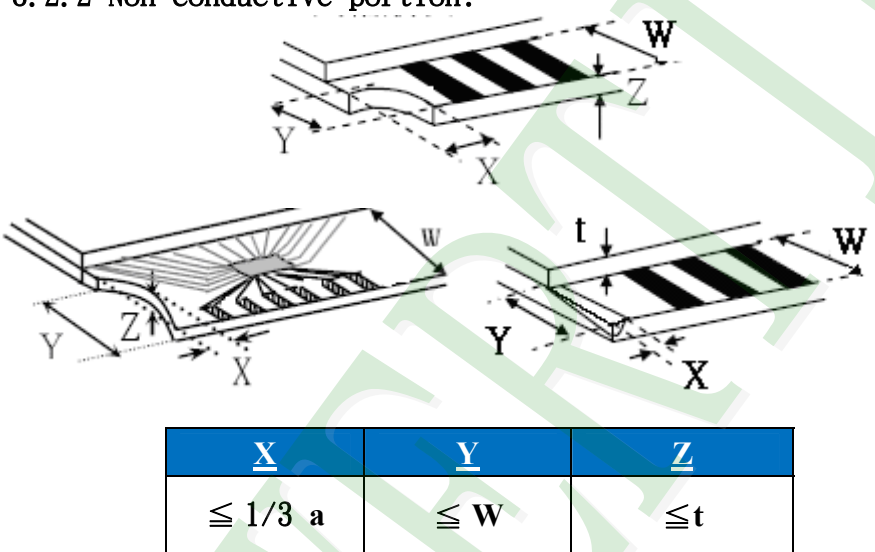
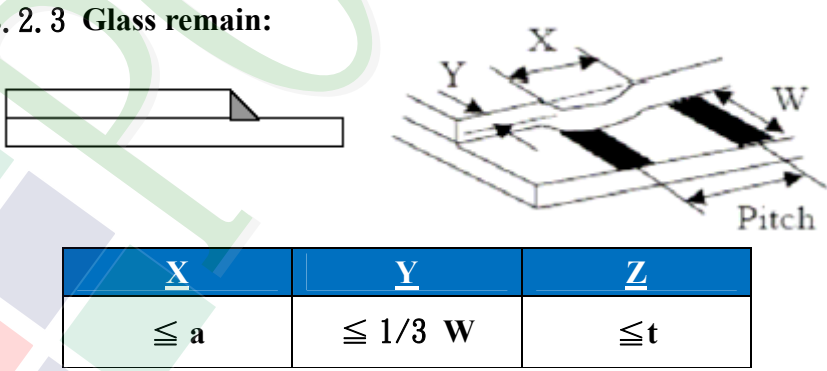
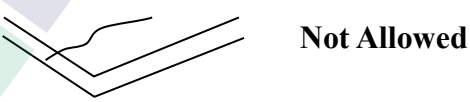
NO	Item	Criterion	Level												
08	The crack of glass	<p>Symbols:</p> <p>X: The length of crack Y: The width of crack. Z: The thickness of crack W: terminal length t: The thickness of glass a: LCD side length</p> <hr/> <p>8.2.2 Non-conductive portion:</p>  <table border="1" data-bbox="625 963 1257 1086"> <thead> <tr> <th><u>X</u></th> <th><u>Y</u></th> <th><u>Z</u></th> </tr> </thead> <tbody> <tr> <td>$\leq 1/3 a$</td> <td>$\leq W$</td> <td>$\leq t$</td> </tr> </tbody> </table> <p>If the chipped area touches the ITO terminal, over 2/3 of the ITO must remain and be inspected according to electrode terminal specifications.</p> <p>8.2.3 Glass remain:</p>  <table border="1" data-bbox="545 1590 1238 1713"> <thead> <tr> <th><u>X</u></th> <th><u>Y</u></th> <th><u>Z</u></th> </tr> </thead> <tbody> <tr> <td>$\leq a$</td> <td>$\leq 1/3 W$</td> <td>$\leq t$</td> </tr> </tbody> </table> <p>8.2.4 Cracking:</p>  <p style="text-align: center;">Not Allowed</p>	<u>X</u>	<u>Y</u>	<u>Z</u>	$\leq 1/3 a$	$\leq W$	$\leq t$	<u>X</u>	<u>Y</u>	<u>Z</u>	$\leq a$	$\leq 1/3 W$	$\leq t$	Minor
		<u>X</u>	<u>Y</u>	<u>Z</u>											
$\leq 1/3 a$	$\leq W$	$\leq t$													
<u>X</u>	<u>Y</u>	<u>Z</u>													
$\leq a$	$\leq 1/3 W$	$\leq t$													

◆Specification For TFT-LCD Module 3.5" ~15" :
(Ver.B01)

<u>NO</u>	<u>Item</u>	<u>Criterion</u>	<u>Level</u>
09	Backlight elements	9. 1 Backlight can't work normally.	Major
		9. 2 Backlight doesn't light or color is wrong.	Major
		9. 3 Illumination source flickers when lit.	Major
10	General appearance	10. 1 Pin type, quantity, dimension must match type in structure diagram.	Major
		10. 2 No short circuits in components on PCB or FPC.	Major
		10. 3 Parts on PCB or FPC must be: no wrong parts, missing parts or excess parts.	Major
		10. 4 Product packaging must the same as specified on packaging specification sheet.	Minor
		10. 5 The folding and peeled off in polarizer are not acceptable.	Minor
		10. 6 The PCB or FPC between B/L assembled distance(PCB or FPC) is ≤ 1.5 mm.	Minor

4. Reliability Test
4.1 Reliability Test Condition
(Ver.B01)

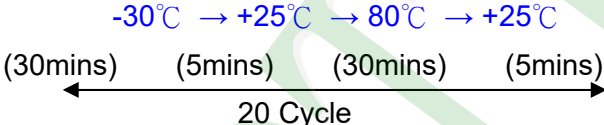
NO.	TEST ITEM	TEST CONDITION										
1	High Temperature Storage Test	Keep in 80 ±5°C 240 hrs										
2	Low Temperature Storage Test	Keep in -30 ±5°C 240 hrs										
3	High Temperature / High Humidity Storage Test	Keep in 60 °C / 90% R.H duration for 240 hrs (Excluding the polarizer)										
4	Temperature Cycling Storage Test	-30°C → +25°C → 80°C → +25°C (30mins) (5mins) (30mins) (5mins)  20 Cycle										
5	ESD Test	Air Discharge: Apply 2 KV with 5 times Discharge for each polarity +/- Contact Discharge: Apply 250 V with 5 times discharge for each polarity +/-										
		1. Temperature ambience: 15°C ~ 35°C 2. Humidity relative: 30% ~ 60% 3. Energy Storage Capacitance(Cs+Cd): 150pF±10% 4. Discharge Resistance(Rd): 330Ω±10% 5. Discharge, mode of operation: Single Discharge (time between successive discharges at least 1 sec) (Tolerance if the output voltage indication: ±5%)										
6	Vibration Test (Packaged)	1. Sine wave 10~55 Hz frequency (1 min/sweep) 2. The amplitude of vibration: 1.5 mm 3. Each direction (X, Y, Z) duration for 2 hrs										
7	Drop Test (Packaged)	<table border="1" style="width: 100%; border-collapse: collapse;"> <thead> <tr> <th style="background-color: #0056b3; color: white;">Packing Weight (Kg)</th> <th style="background-color: #0056b3; color: white;">Drop Height (cm)</th> </tr> </thead> <tbody> <tr> <td style="text-align: center;">0 ~ 45.4</td> <td style="text-align: center;">122</td> </tr> <tr> <td style="text-align: center;">45.4 ~ 90.8</td> <td style="text-align: center;">76</td> </tr> <tr> <td style="text-align: center;">90.8 ~ 454</td> <td style="text-align: center;">61</td> </tr> <tr> <td style="text-align: center;">Over 454</td> <td style="text-align: center;">46</td> </tr> </tbody> </table>	Packing Weight (Kg)	Drop Height (cm)	0 ~ 45.4	122	45.4 ~ 90.8	76	90.8 ~ 454	61	Over 454	46
		Packing Weight (Kg)	Drop Height (cm)									
		0 ~ 45.4	122									
		45.4 ~ 90.8	76									
		90.8 ~ 454	61									
Over 454	46											
0 ~ 45.4	122											
45.4 ~ 90.8	76											
90.8 ~ 454	61											
Over 454	46											
Drop Direction : ※1 corner / 3 edges / 6 sides each 1time												

◎Result Evaluation Criteria :

 Under the display quality test conditions with normal operations with normal operation state.
 Do not change these conditions as such changes may affect practical display function.

(Normal operation state)

Temperature : +20~30°C

Humidity : 50~70%

Atmospheric pressure : 86~106Kpa

5. PRECAUTION RELATING PRODUCT HANDLING

5.1 SAFETY

- 5.1.1 If the LCD panel breaks, be careful not to get the liquid crystal to touch your skin.
- 5.1.2 If the liquid crystal touches your skin or clothes, please wash it off immediately by using soap and water.

5.2 HANDLING

- 5.2.1 Avoid any strong mechanical shock which can break the glass.
- 5.2.2 Avoid static electricity which can damage the CMOS LSI—When working with the module, be sure to ground your body and any electrical equipment you may be using.
- 5.2.3 Do not remove the panel or frame from the module.
- 5.2.4 The polarizing plate of the display is very fragile. So, please handle it very carefully, do not touch, push or rub the exposed polarizing with anything harder than an HB pencil lead (glass, tweezers, etc.)
- 5.2.5 Do not wipe the polarizing plate with a dry cloth, as it may easily scratch the surface of plate.
- 5.2.6 Do not touch the display area with bare hands, this will stain the display area.
- 5.2.7 Do not use ketonic solvent & aromatic solvent. Use with a soft cloth soaked with a cleaning naphtha solvent.
- 5.2.8 To control temperature and time of soldering is $320 \pm 10^{\circ}\text{C}$ and 3 ~ 5 sec.
- 5.2.9 To avoid liquid (include organic solvent) stained on LCM.
- 5.2.10 Caution! (LCM products with Capacitive Touch Panel)
Strong EMI-sources such as switch-mode power supplies (SPS) can lead to touch malfunction (e.g., ghost-touches). Therefore, the touch needs to be thoroughly tested inside the target application.
- 5.2.11 CAUTION: Continuously displaying same static image will result in high possibility of image sticking/image burn-in effect due to TFT panel characteristic.
- 5.2.12 Double-sided tape designed to be attached with the customer's mechanical device, please follow up the rules and regulations published by the original manufacturer of double-side tape for the attachment operation.

5.3 STORAGE

- 5.3.1 Store the panel or module in a dark place where the temperature is $25^{\circ}\text{C} \pm 5^{\circ}\text{C}$ and the humidity is below 65% RH.
- 5.3.2 Do not place the module near organics solvents or corrosive gases.
- 5.3.3 Do not crush, shake, or jolt the module.

5.4 TERMS OF WARRANTY

- 5.4.1 Applicable warrant period
The period is within thirteen months since the date of shipping out under normal using and storage conditions.
- 5.4.2 Unaccepted responsibility
This product has been manufactured to your company's specification as a part for use in your company's general electronic products. It is guaranteed to perform according to delivery specifications. For any other use apart from general electronic equipment, we cannot take responsibility if the product is used in nuclear power control equipment, aerospace equipment, fire and security systems or any other applications in which there is a direct risk to human life and where extremely high levels of reliability are required.

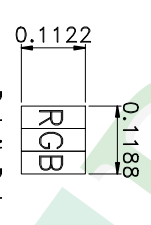
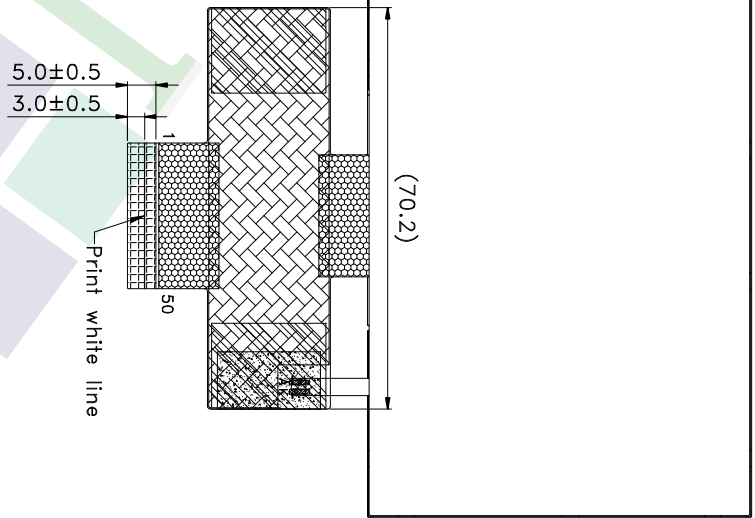
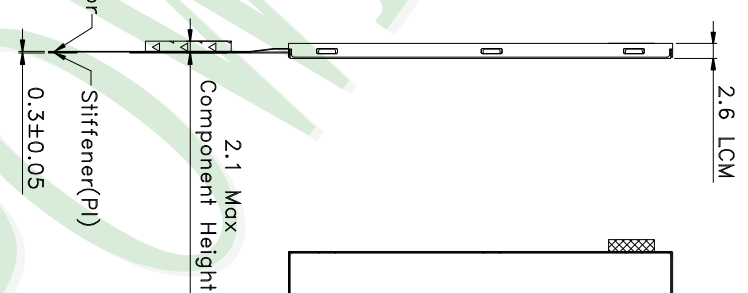
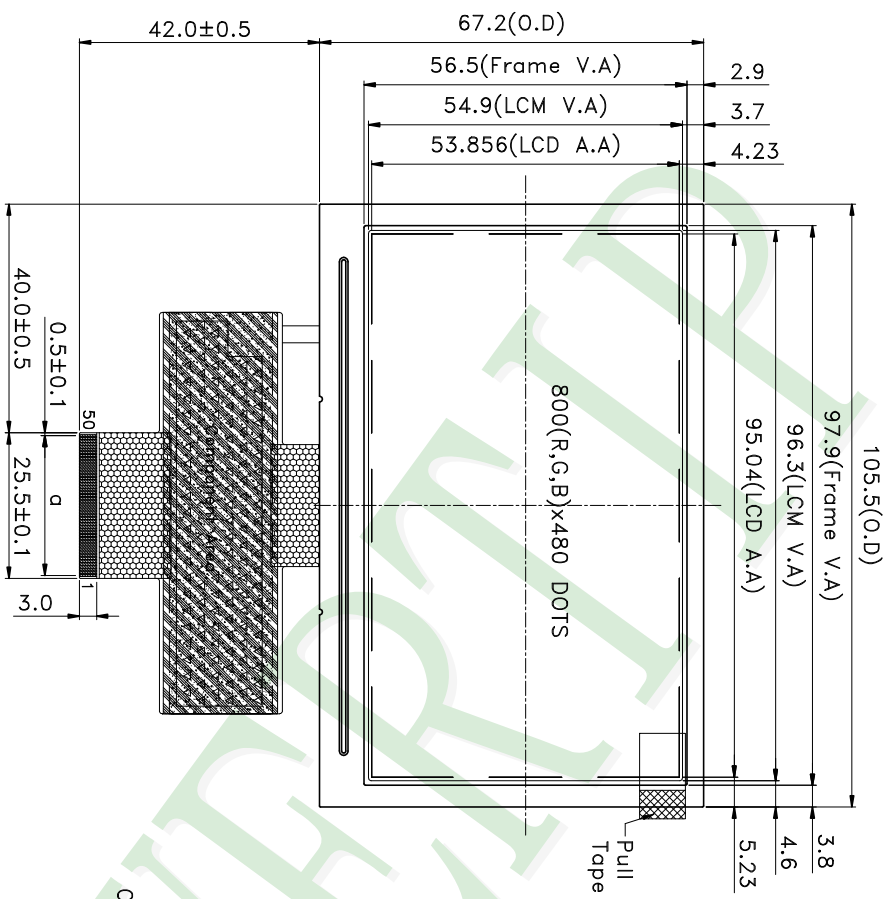

- NOTES:
- LCD TYPE:TFT LCD
 - LCD DISPLAY:Normally Black/TRANSMISSIVE
 - The tolerance unless classified $\pm 0.3\text{mm}$
 - a:P0.5*49=24.5 ± 0.05 ; W=0.35 ± 0.05
 - :Kapton tape;
 - ▨:Component area;
 - ▩:Stiffener(SUS $t=0.2\text{mm}$ to GND)
 - ▧:Aluminum Foil Conductive Adhesive Tape;
 - ▦:EMI Film;
 - LCM FPC suggested connector : "Hirose" FH12A-50S-0.5SH or compatible.

007			
006			
005			
004			
003			
002			
001	NEW DRAWING	Clare	2024/6/21
REV	REV BY	REVISER	DATE

PART NO:		PH800480T028-ZHA	
DRAWING NAME:		LMD-PH800480T028-ZHA	
TITLE:		LCD MODULE DRAWING	
Design	Clare Chen	Check	Tina Chen
Approve	Bright Chiang		

久正光電股份有限公司
POWER TIP TECHNOLOGY CORPORATION

Unit	MM	Surface		Precision Level
Scale	FIT	Material		
Page	1/1	Thickness		
Quantity				
Tolerance (mm)				
1 ~ 4				
4 ~ 16				
16 ~ 63				
63 ~ 250				
250 ~ 1000				

Approve	Check	Contact
Bright	Tina	Clare

1. 包裝材料規格表(Packaging Material) : (per carton)

No.	Item	Model	Dimensions (mm)	1Pcs Weight	Quantity	Total Weight
1	成品 (LCM)	PH800480T028-ZHA	105.5 X 67.2	0.0398	216	8.5968
2	多層薄膜(1)POF	OTFILM0BA03ABA	19"X350X0.015	—	6	—
3	TRAY 盤 (2)Tray	TYSG000000227	352 X 260 X 10.8	0.1	60	6.0
4	內盒(3)Product Box	BX36627063ABBA	383 X 270 X 66	0.182	6	1.092
5	保利龍板(4)Pollylon board	OTPLB00PL08ABA	550 X 393 X 20	0.0284	2	0.0568
6	外紙箱(5)Carton	BX57041027CCBA	570 X 410 X 265	1.0	1	1.0
7						
8						
9						

2. 一整箱總重量 (Total LCD Weight in carton) : 16.75 Kg±10%

3. 單箱數量規格表(Packaging Specifications and Quantity) :

(1) LCM quantity per box : no per tray	4	x no of tray	9	=	36
(2) Total LCM quantity in carton : quantity per box	36	x no of boxes	6	=	216

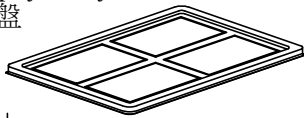
Use empty tray
空盤

+

Put products into the tray

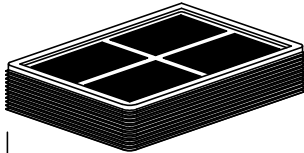

⇓

Tray stacking

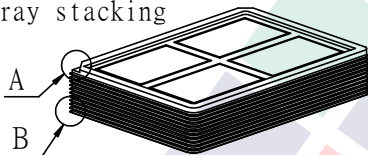
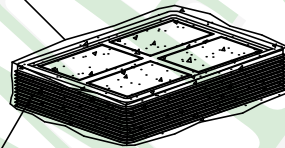
(1) 多層薄膜
POF(2) TRAY 盤
Tray

⇓

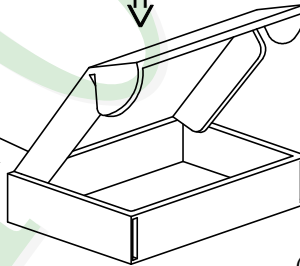
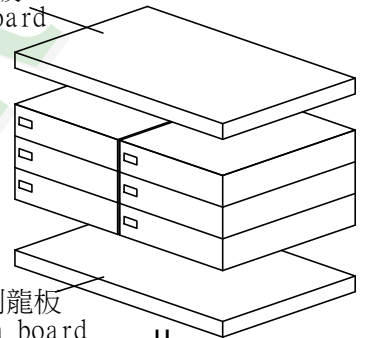
(3) 內盒
Product Box(4) 保利龍板
Pollylon board(4) 保利龍板
Pollylon board

⇓

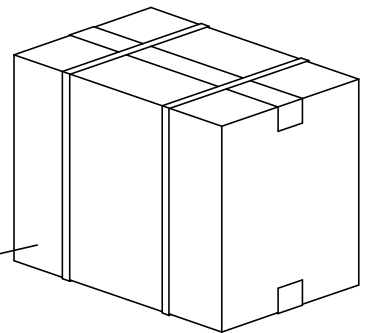
(5) 外紙箱
Carton

特 記 事 項 (REMARK)

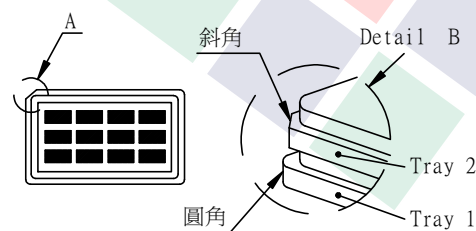
5. 外購tray: TY00000000392
自製tray: TYSG0000002274. TRAY盤相疊時, 需旋轉180度, 請詳見B視圖
Rotate tray 180 degrees and place on top of stack.
Check the tray stack using Fig. B.