

APPROVE:

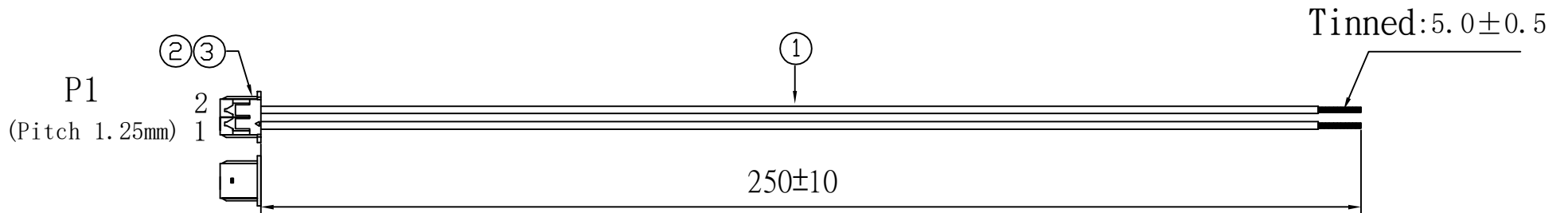

WIRING TABLE

Packing : 50PCS/bunch

P1	WIRE COLOR	TIN
1	BLACK	5.0±0.5
2	RED	5.0±0.5

3	TERMINAL	11251H00-2P/1251-2Y	2	JCTC/AMA
2	HOUSING	11251TOP-2E/1251-T	1	JCTC/AMA
1	WIRE	UL1061 28AWG OD:0.9mm	2	Hongmeng/DC

WIRE LENGTH					ITEM	NAME	SPEC	Q`TY	VENDOR
TITLE	WIRE HARNESS			UNIT	m/m	APPROVE	CHECKED	DRAWN	晨星電子股份有限公司 CSTAR Electronics International Inc CUSTOMER A-Switch GmbH
ORD.NO.	SCALE	FREE	SHEET : 1 OF 1		Jen	SC	Marco		
BOM NO.	ECO.NO.	REV.	A						
CUSTOMER PART NO.	Power supply cable	DWG NO.	CST-AR-8203		2024.05.06	2024.05.06	2024.05.06		

环保物料

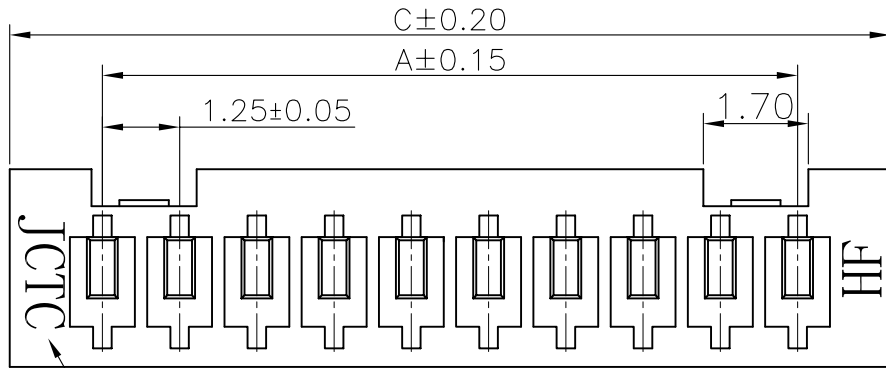

4P~20P

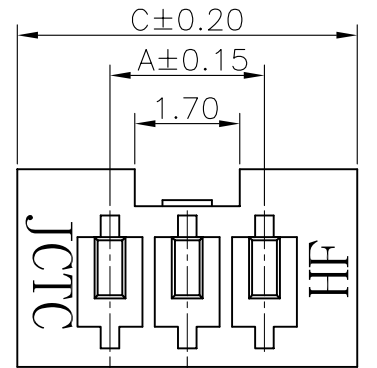
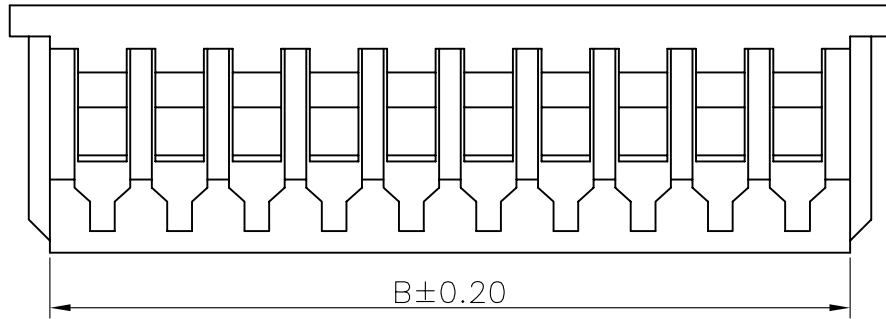

2P~3P

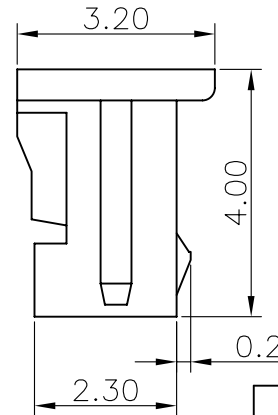

Specifications:
 Rated Voltage : 125V AC/DC
 Rated Current : 1A AC,DC
 Withstand Voltage : 800V AC/minute
 Contact Resistance : 20mΩ(MAX.)
 Insulation Resistance : 1000MΩ(MIN.)
 Temperature Range : -25℃~+85℃
 Pitch Between Poles : 1.25mm

Dimensional Ordering Information:

Circuits	Part No	Dimensions		
		A	B	C
2	2P		3.00	4.25
3	3P	2.50	4.25	5.50
4	4P	3.75	5.50	6.75
5	5P	5.00	6.75	8.00
6	6P	6.25	8.00	9.25
7	7P	7.50	9.25	10.50
8	8P	8.75	10.50	11.75
9	9P	10.00	11.75	13.00
10	10P	11.25	13.00	14.25
11	11P	12.50	14.25	15.50
12	12P	13.75	15.50	16.75
13	13P	15.00	16.75	18.00
14	14P	16.25	18.00	19.25
15	15P	17.50	19.25	20.50
20	20P	23.75	25.50	26.75

11251H00-NPX-XX-HF-NK
 ① ② ③ ④ ⑤ ⑥ ⑦

- ① Series No.
- ② H90 : Side Contact
H00 : Up Contact
- ③ No. of Circuits
- ④ X : Product color(A--Y)
Blank : Natural type
- ⑤ PT : PBT
Blank : Nylon 66
- ⑥ HF : Halogen Free
- ⑦ NK : No Mark
Blank : Mark

Suitable for JCTC 11251 series terminal

Part No.	Material	Color
11251H00-NP	Nylon 66,UL94V-0	本色
11251H00-NP-NK	Nylon 66,UL94V-0	本色
11251H00-NP-PT	PBT,UL94V-0	本色
11251H00-NP-PT-NK	PBT,UL94V-0	本色
11251H00-NP-HF	Nylon 66,UL94V-0	本色
11251H00-NP-HF-NK	Nylon 66,UL94V-0	本色
11251H00-NPA	Nylon 66,UL94V-0	黑色
11251H00-NPE	Nylon 66,UL94V-0	黄色

					一般公差 GENERAL TOLERANCE		绘图 DR.	陈干	东莞市胜蓝电子有限公司 富强电子厂	料号 PART NO.		
					X.X ±0.25	X' ±5'	校对 CHK.			11251H00-NPX-XX-XX-XX		
					X.XX ±0.15	X.X' ±2'	审核 CHK.			文件编号 NUMBER		
					X.XXX ±0.08	▲ MAJOR DIM.	核准 APPD.		品名 TITLE			
C0	09.11.25	换图框发行	龚友莲	唐海江	单位 UNIT			MX 1.25mm PITCH HOUSING			ENDE05	
版次 REV.	日期 DATE	变更内容 DESCRIPTION	审核 CHK.	核准 APPD.	mm			比例 SCALE	SHEET	版次 REV.		
A	B	C	D	E	F			1/1	1/1	C0		

环保物料

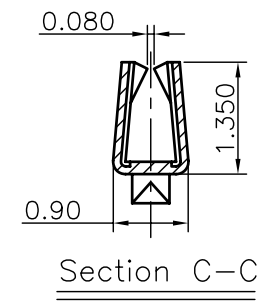
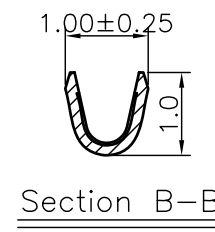
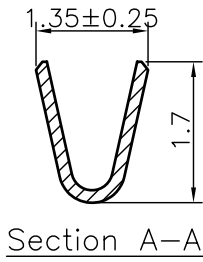
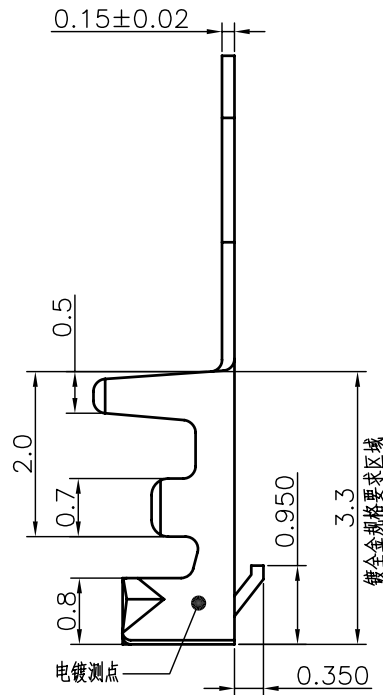
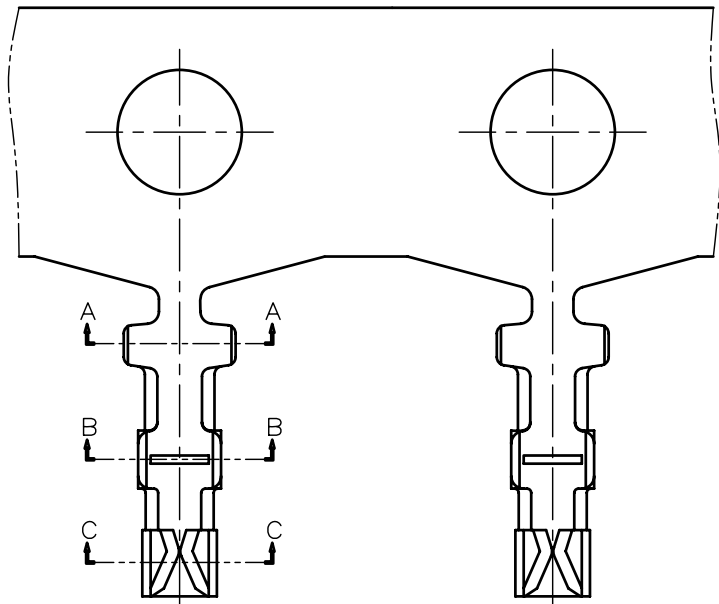

Note: 11251TOP-XX-C-NK
 NK: No Mark
 表示: 有缝隙规格

Finish

5A--1u"	5B--2u"	5C--3u"
5D--4u"	5E--5u"	5F--10u"
5G--15u"	5H--30u"	5I--50u"

Part No	Wire Range	Insulation O.D.	Material	Finish	Qty/reel
11251TOP-2E-C-XX	AWG#28 ~ #32	1.00mm(max)	Phosphor Bronze	Tin-plated	15,000 pcs
11251TOP-5X-C-XX	AWG#28 ~ #32	1.00mm(max)	Phosphor Bronze	Gold-plated overall	15,000 pcs

					一般公差 GENERAL TOLERANCE		绘图 DR.		EAST		JCTC 东莞市胜蓝电子有限公司 — 富强电子厂 —			料号 PART NO. 11251TOP-XX-C-XX			
					X.X ±0.25	X' ±5°	校对 CHK.		龚友连					文件编号 NUMBER ENDE05			
					X.XX ±0.15	X.X' ±2°	审核 CHK.		唐海江		品名 TITLE MX1.25 端子			比例 SCALE 1/1		SHEET 1/1	版次 REV. C1
					X.XXX ±0.08	▲ MAJOR DIM.	核准 APPD.		王志刚								
					单位 UNIT mm												
版次 REV.	日期 DATE	变更内容 DESCRIPTION	审核 CHK.	核准 APPD.													

REV.	ECN NO.	LOCAS.	DESCRIPTION	DATE	DESIGN
1.08			更新图面	2011.06.22	薛志敏

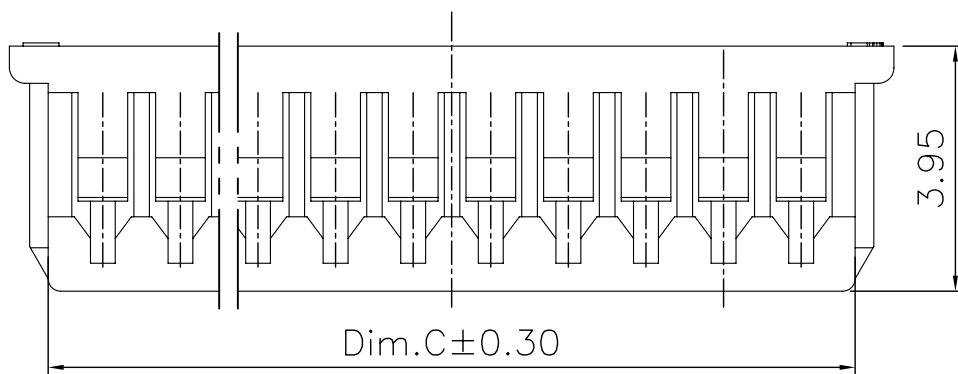
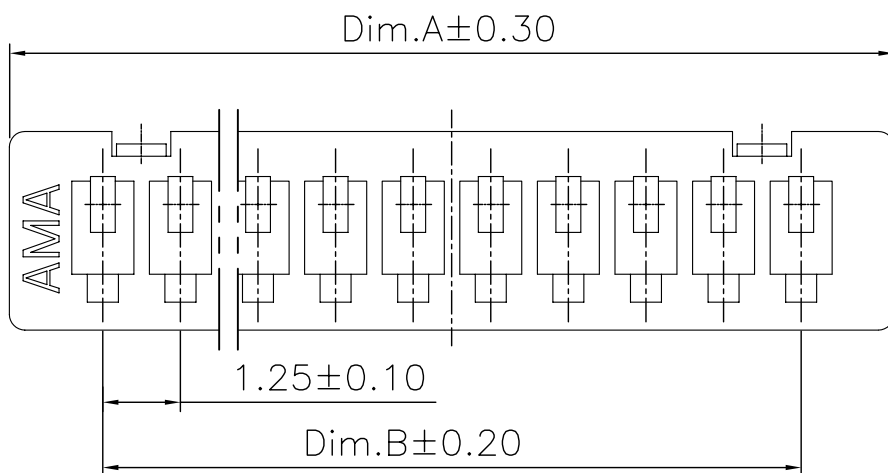

技术要求:

- 1) Material: PBT+8%GF (UL94V-0), COLOR: 本色;
- 2) 适用温度: -25到+85摄氏度。
- 3) 塑件表面平整、光洁、无毛刺、气泡、变形、浇口无拉伤、缺料等不良现象。

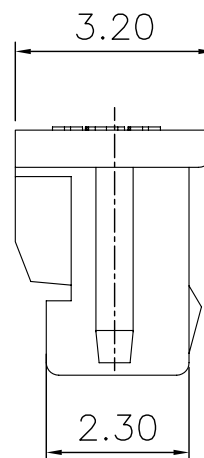

1251-15Y	20.50	17.50	19.25
1251-14Y	19.25	16.25	18.00
1251-13Y	18.00	15.00	16.75
1251-12Y	16.75	13.75	15.50
1251-11Y	15.50	12.50	14.25
1251-10Y	14.25	11.25	13.00
1251-9Y	13.00	10.00	11.75
1251-8Y	11.75	8.75	10.50
1251-7Y	10.50	7.50	9.25
1251-6Y	9.25	6.25	8.00
1251-5Y	8.00	5.00	6.75
1251-4Y	6.75	3.75	5.50
1251-3Y	5.50	2.50	4.25
1251-2Y	4.25	1.25	3.00
规格	Dim.A	Dim.B	Dim.C

DIM	TOL	DIM	TOL
X.		X'	±2'
X.X	±0.30	X.X'	
X.XX	±0.20	X.XX'	
X.XXX	±0.10	X.XXX'	

AMA 浙江正理生能科技有限公司
Zhejiang AMA & Hien technology Co., LTD

DRAW NO.	DATE	MATERIAL: SEE NOTE	DRAW NAME:	
DESIGN: 薛志敏	2011.06.22	FINISH:	1251-nY	
CHECK: 薛树超	2011.06.22	FILE:	Customer drawing	
REVIEW:		P/N NO.	MODEL:	
APPROVED 陈国光	2011.06.22	REV.1.08	SCALE N/A	UNIT: mm
				SHEET: 1/1

REV.	ECN NO.	LOCAS.	DESCRIPTION	DATE	DESIGN
1.08			更新图面	2011.06.22	薛志敏

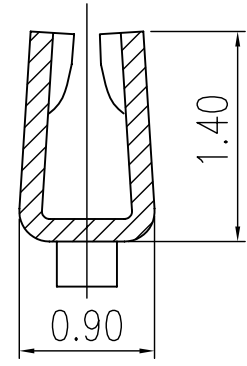
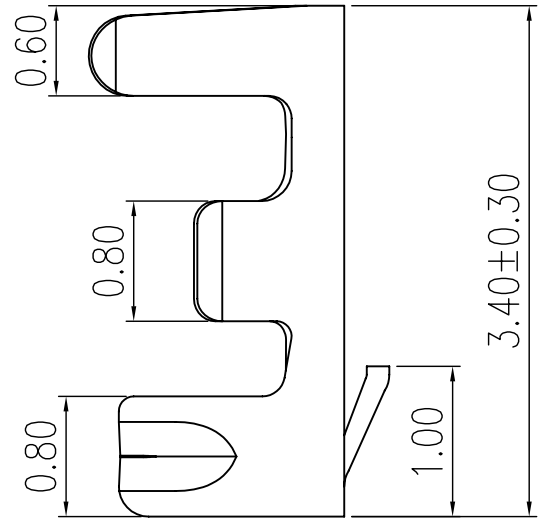
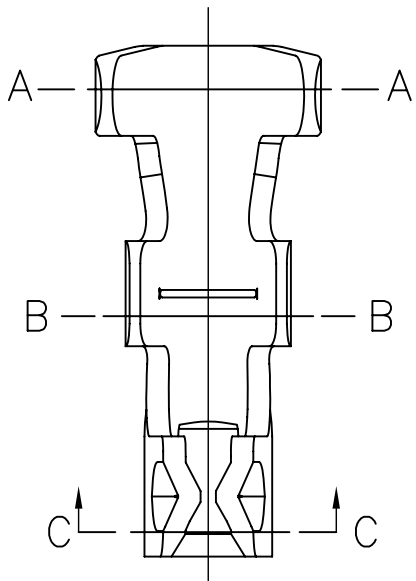

SECTION C-C

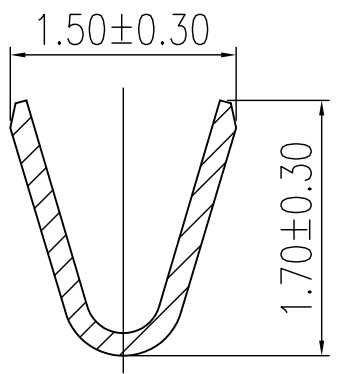

SECTION A-A

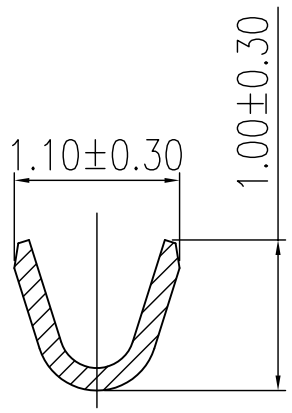

SECTION B-B

技术要求:

- 1) 材质: 磷青铜 (QSn6.5-0.1), 厚度: 0.15mm.
- 2) 电镀要求: 镀锡60u"以上.
- 3) 适用条件: 温度-25到+85摄氏度, 相对湿度93%.
- 4) 适用导线范围: AWG#28-#32.

AMA 浙江正理生能科技有限公司
Zhejiang AMA & Hien technology Co., LTD

DIM	TOL	DIM	TOL
X.		X'	±3.0'
X.X	±0.30	X.X'	
X.XX	±0.20	X.XX'	
X.XXX	±0.10	X.XXX'	

DRAW NO.		DATE	2011.06.22	MATERIAL:	见技术要求	DRAW NAME:	1251-T
DESIGN:	薛志敏	CHECK:	薛树超	FINISH:	见技术要求	CUSTOMER DRAWING	
REVIEW:		APPROVED	陈国光	FILE:		MODEL:	
				P/N.		UNIT:	mm
				REV. 1.08	SCALE N/A	SHEET:	1/1

